

# CHINOOK

*✓ Club Lounge*

*✓ Twin Beds*

*✓ Dinette*

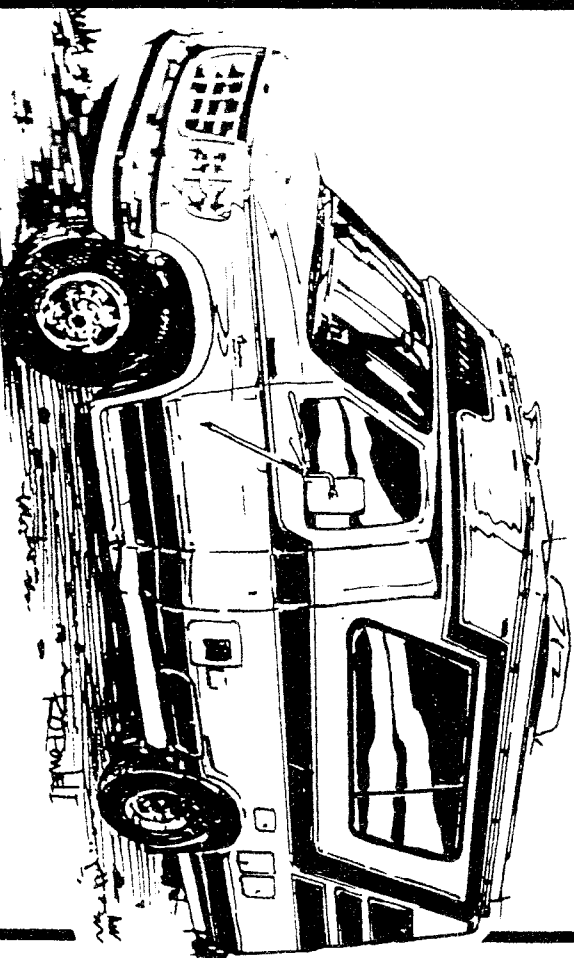

## OWNER'S MANUAL

### TABLE OF CONTENTS

Service .....	1
General Operation .....	3
Electrical System .....	7
110 Electrical Diagram (Premier/Concourse) .....	9
110 VAC Breaker Panel Diagram (Premier Only) .....	10
12 VDC Wiring Diagram (Premier Only) .....	11
With Factory Dual Batteries Diagram .....	12
12 VDC Wiring Diagram (Concourse Only) .....	13
Without Factory RV Battery Diagram .....	14
110 VAC Breaker Panel Diagram (Concourse Only) .....	15
Running Lights Diagram .....	16
Water System .....	18
LP Gas System .....	21
General Maintenance .....	23
Preventive Maintenance .....	26
Specifications .....	27

## **SERVICE**

Service is important to you — and it is equally important to us. When you buy a Chinook, you can expect years of carefree service with regular but minimal maintenance. Our reputation has been built on that premise.

### **Double service backup**

Your Chinook dealer's service department will promptly handle any operational difficulty you may have with your motorhome. If such a problem is not resolved to your complete satisfaction, please take these steps:

1. Discuss the problem with the general manager or owner of your dealership. Give him the opportunity to work with his service crew in solving it.
2. If the difficulty cannot be resolved to your satisfaction by your local dealer, contact your nearest Chinook factory for assistance by calling: (509) 248-9026.

This double service backup is your best assurance that you have made the right decision in choosing a Chinook.

### **Your dealer's responsibilities . . .**

Your Chinook dealer has thoroughly inspected your motorhome, retesting the lighting, plumbing, water and heating systems for any malfunctions that may have occurred during shipment from the factory. All appliances are checked by the dealer at the time of purchase. He is obligated to explain and demonstrate the operation of your equipment and accessories, answer questions and make minor adjustments. (For further instructions on operation, maintenance and warranties, please refer to the individual manuals or instruction sheets provided.)

If you should require service and replacement of defective equipment, make your request directly to the manufacturer of the appliance or accessory involved. In contacting any manufacturer, dealer or Chinook factory for service or information, be sure to include all the following:

1. Date of purchase along with stock or vehicle identification number.
2. Serial or model number and complete description of the product.
3. Detailed explanation of the difficulty you are having.

Replacement parts should be purchased through the manufacturer or supplier or through your local dealer or supply store. If you have difficulty obtaining parts or service, contact the Chinook factory for assistance.

## **SERVICE**

### **Register your warranty today!**

Your first responsibility at time of delivery is to register your warranty . . . so mail in your properly completed warranty registration card today.

Only by filling out and submitting your registration card can you be assured of the guarantees it provides. This card is for your protection as a consumer — use it now!

Remember, warranties do not cover normal maintenance service or adjustments which may become necessary through normal extended use. That is why, after you have met your first obligation by submitting your warranty card, you must be prepared for an on-going responsibility: preventive maintenance.

You have just bought the finest motorhome in the world . . . and we want you to enjoy every mile of it. All you have to do is rely on the tips and recommendations offered on the following pages.

### **Ford Motor Home Owners Service Locator Hotline**

1-800-444-3311  
provides 24-hour, 7-day-a-week assistance in contacting a dealership,  
arranging a service appointment and providing a dealership  
contact person name.  
Can also assist in locating towing service, if needed.

# GENERAL OPERATION

## Planning your trip, being prepared

Planning your trip is an exciting time — and a time when you are likely to forget something important in your last minute rush to get ready.

Being properly prepared is the key to getting the most enjoyment from your motorhome, and that's why we are offering the following suggestions as a guide: Review them before starting out . . . refer to them when you are on the road . . . and then note the items you have forgotten so your next trip will be even more fun.

Plan your trip carefully. Consult maps and guide books so you will be familiar with road conditions, roadside parks, rest areas and campsites.

Be sure that all your equipment is serviced and ready for travel.

### Check all of the following:

1. All fluids, including motorhome engine crankcase oil, transmission fluid, power steering fluid, radiator reservoir level, master cylinder brake fluid, electrolyte level of batteries, windshield water reservoir level.
2. Inspect wheel lugs for tightness.
3. Examine all tires for road damage. Inflate to the pressure recommended by the chassis manufacturer, and note that this pressure is for cold tires (see chassis operator's manual).
4. Check oil level in the generator power plant (if installed). Refer to the instructions and the maintenance manual provided by the generator manufacturer for pre-use service requirements. Make sure extra oil and other supplies are provided if the motorhome is to be used for extended periods.
5. Make certain your jack handle and lug wrench are properly stowed and in good working order.
6. Check to see that your 120-volt power cord is stowed in its compartment.
7. Be sure your fire extinguisher is secured and easily accessible.
8. Check to see that such accessories as the plastic sewer hose with fittings and a water supply hose (a garden hose approved for 125 psi service is adequate) are on board.
9. Fill water tank, if required (see section on Chinook water system).
10. Make sure drain line cap and holding tank knife valves are closed and secured.

# GENERAL OPERATION

## Check all of the following (continued)

11. Check all stop lights, running lights and other safety items.
12. Put your Chinook motorhome items in "travel" condition. This means following such common-sense procedures as securing any loose items that could shift while you are traveling. For example, secure refrigerator contents — place lids on containers of liquids — and secure locking latch on refrigerator door. Be sure cabinet contents are secured and doors are tightly closed. Close and lock all exterior doors and windows.
13. Always carry spare fuses of every size used in your vehicle.
14. Adjust side view mirrors for maximum visibility.
15. Fill the fuel tank, using only the fuel recommended in the chassis operator's manual.
16. Fill the LP-gas tank if required.

**WARNING! ALWAYS EXTINGUISH PILOT LIGHTS AND OPEN FLAMES ON APPLIANCES BEFORE FILLING YOUR GASOLINE OR LPG TANK.**

## A word about weight and weighing

Your Chinook motorhome is designed to carry the loads defined by its gross axle weight rating and gross vehicle weight rating, both of which are for a fully loaded vehicle, including passengers and belongings.

An excellent practice when loading your motorhome for a trip is to store heavy articles low and light articles high. In this way you will improve the road handling and stability of your vehicle.

Rated weight capacities for your motorhome are listed on the vehicle identification table on the driver's side door post. If you are in doubt about the load you are carrying, weigh your vehicle at a public scale.

**IMPORTANT NOTE:** Exceeding the weight capacities of your motorhome can cause undesirable handling characteristics and may create a safety hazard. If you modify your motorhome by adding racks not supplied by the manufacturer your warranty may become invalid.

Another reason you should check vehicle weight periodically is to obtain optimum mileage from your tires. You also will find that handling improves when you are within prescribed weight capacities.

# GENERAL OPERATION

---

## Starting up and ready to leave . . .

---

With your preparation and final checkouts all completed, you're ready to leave. But first, some good advice:

1. When starting, warming up and operating your engine, you'll get the best results and the performance you want by following the instructions in your chassis operator's manual.
2. Seat belts are a vital safety feature in your Chinook motorhome. All seat belts should be fastened while your motorhome is in motion. For your protection and the safety of your family, all seats designed to carry passengers are equipped with seat belts. *Seats not equipped with belts are not to be occupied while the vehicle is in motion.*

## At last, you're on the road!

---

Once you've become accustomed to the feel of the controls and can accurately gauge distances and the length and width of the vehicle, your Chinook motorhome is like driving your family car. It's easy to handle, to maneuver and to park. But be cautious when maneuvering so you allow for the extra length and width of the motorhome. Check your side view mirrors frequently for approaching traffic from the rear.

When on the road, remember that higher speeds may result in a sharp increase in fuel consumption.

Always allow for the extra height of your Chinook. It's 9'2" without roof air conditioning, 9'9" with it. Avoid low overhead clearance areas such as low roofs at gasoline service stations. This is especially important as you drive with the overhead vent open or if you have a roof pod or air conditioner.

When parking, remember that the rear wheels are wider than the motorhome. And when parking on an incline, your front wheels should be turned into the curb in the direction of the roll as an aid to your parking brake.

# GENERAL OPERATION

---

## At last, you're on the road!

---

### Changing a Tire

See your chassis operator's manual for tire changing instructions. Your fully loaded motorhome is very heavy, and the lug nuts usually are set with a power torque wrench which makes them extremely difficult to remove. Obtain road service whenever possible, and only attempt to change tires yourself when it is an emergency situation.

**WARNING:** Loosening the rear lug nuts may release both outside and inside wheels. Do not attempt to remove lugs without having your jack in position to absorb the full weight of the motorhome.

### Safety Equipment

Your motorhome is equipped with a properly rated fire extinguisher which is located in the rear doorway. Check your extinguisher on a regular basis for proper charge, any damage and to make sure it is operable.

### Emergency Exit

The driver-side door is designated for use as an emergency exit. Keep it unobstructed and free to open completely in an emergency.

## **ELECTRICAL SYSTEM**

---

Three sources of electrical power are available in Chinook motorhomes: 12 VDC auxiliary battery, 120 VAC from an external source through a 26 ft. power cord, and 120 VAC from an optional generator set.

### **12 VDC auxiliary battery**

This unit is located under the wardrobe drawer of Chevy and diesel Ford chassis and under the hood in a standard Ford chassis. It is contained in a corrosion-resistant, sealed battery box. When under a charge, these batteries produce hydrogen gas. For safety, the battery box is vented to the exterior at the top of the box by a flexible hose. The box also is vented at the bottom to prevent accumulation of liquids. Be certain that the flexible hose is not damaged, that all joints and connections are tight and that vents remain unobstructed.

### **Battery Charging**

Two methods of charging the auxiliary battery are used. While the vehicle is in operation, the battery is continuously charged by the chassis electrical system. When the ignition switch is turned off, an automatic device isolates the auxiliary battery from the chassis system to prevent electrical drain on the vehicle battery. When parked, the auxiliary can be charged by a special circuit in the 12 VDC converter when the 26 ft. power cord is connected to a 120 VAC external power source or when the optional generator is in operation.

### **Power Off**

The power off is to insure that no battery power is lost over a long storage period. However, during operation of your motorhome it should be on to allow charging of the RV battery. The power off switch is located in the left of the driver seat base. Power off switch does not shut 12V off when plugged into 110V.

### **Emergency Start Switch**

Emergency start switch phases your start battery with your R.V. battery to insure that your motorhome will always start. This switch is located on your dash panel left of the steering wheel.

### **Interior Lighting and Appliances**

All interior lights and those appliances requiring electrical power operate on 12 VDC. The refrigerator, however, may be operated by 12 VDC, 120 VAC or LP-gas. Refer to refrigerator manufacturer's operating instructions for details of operation. The microwave operates on 120 VAC only.

## **ELECTRICAL SYSTEM**

---

### **120 VAC external source (continued)**

#### **Circuit protection**

The 120 VAC distribution panel is in a compartment under the sink cab. Breakers are used to protect the 120 VAC electrical system. These circuit breakers do not reset automatically and must be turned off, then returned to the "On" position. Continued tripping of the breakers indicates an electrical problem that should be checked by a repairman.

#### **Generator (optional)**

The manufacturer of this generator has provided complete operating instructions for the unit installed by Chinook. These instructions, contained in the owner information and warranty package, should be read completely before attempting to operate the generator.

CHINOOK PREMIER/CONCOURSE  
110 ELECTRICAL

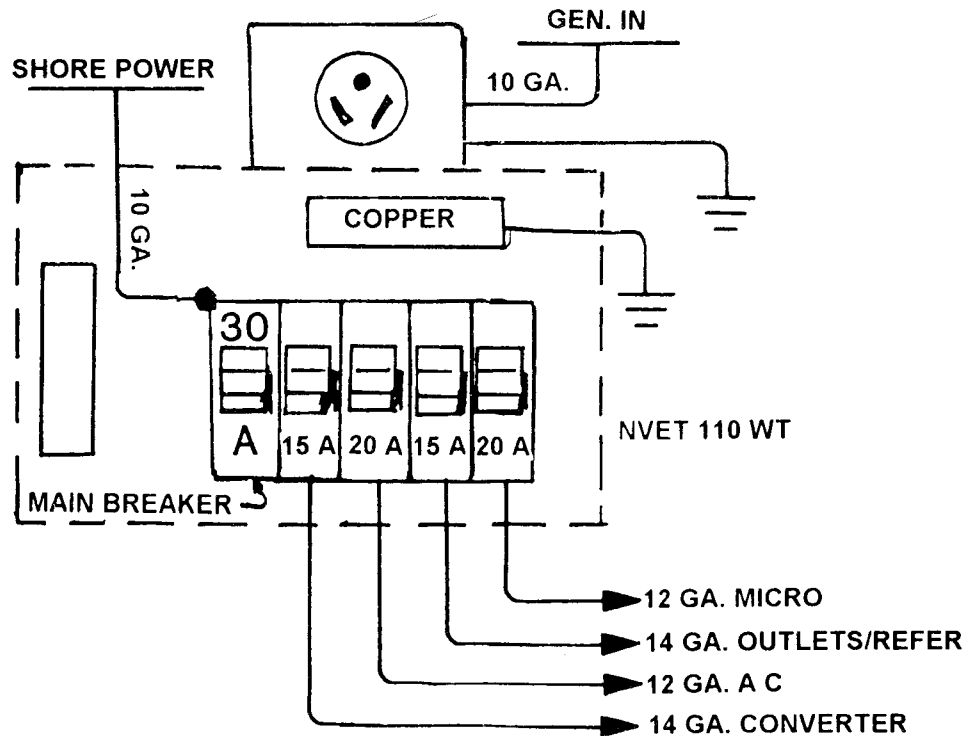
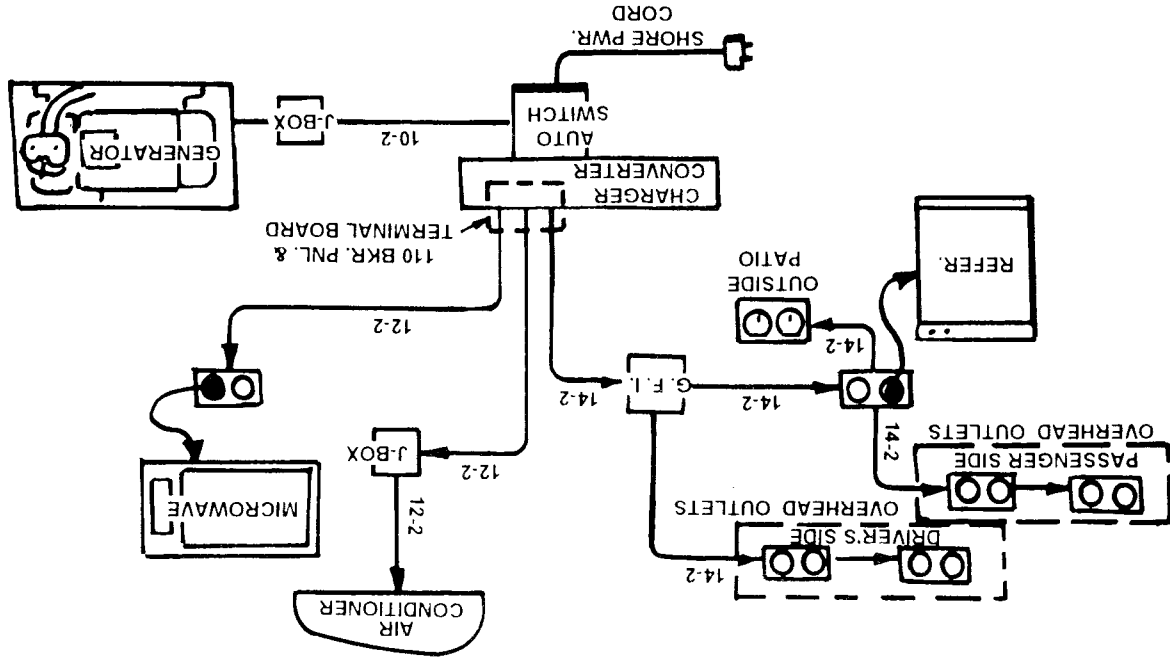

110 VAC BREAKER PANEL DIAGRAM  
PREMIER ONLY







# 110 VAC BREAKER PANEL DIAGRAM CONCOURSE ONLY

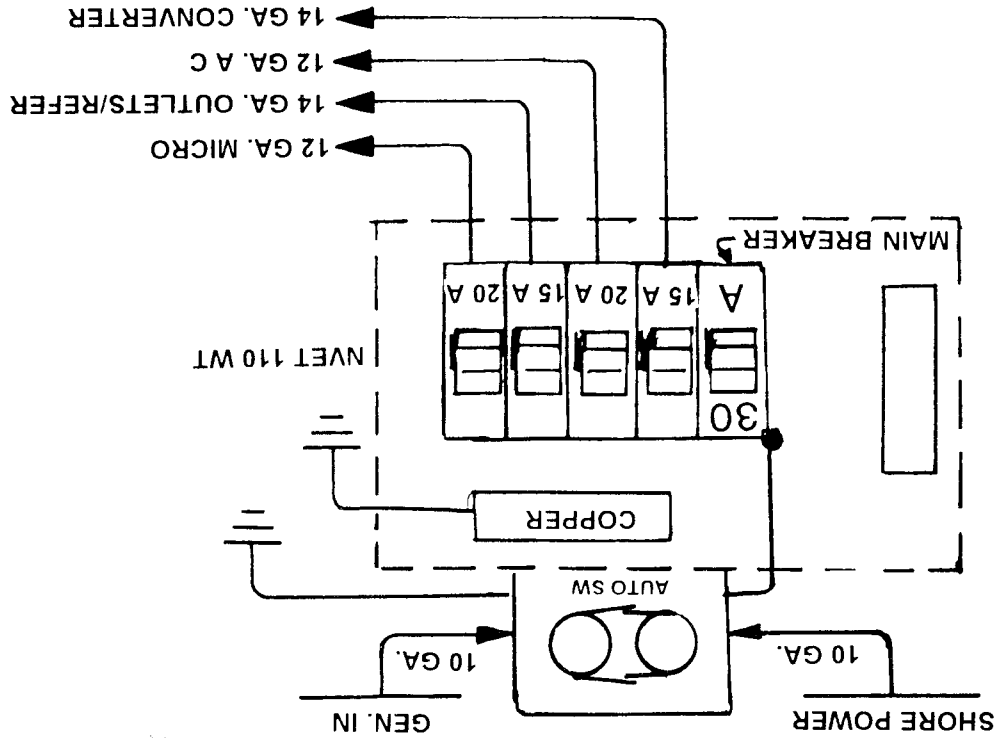

**FACTORY**  
 BROWN W/WHITE 12 VDC 14 GA.  
 WHITE - GROUND 12 GA.

← MARKER LIGHTS →

**CHINOOK**  
 BROWN - 12 VDC 18 GA  
 WHITE - GROUND 18 GA

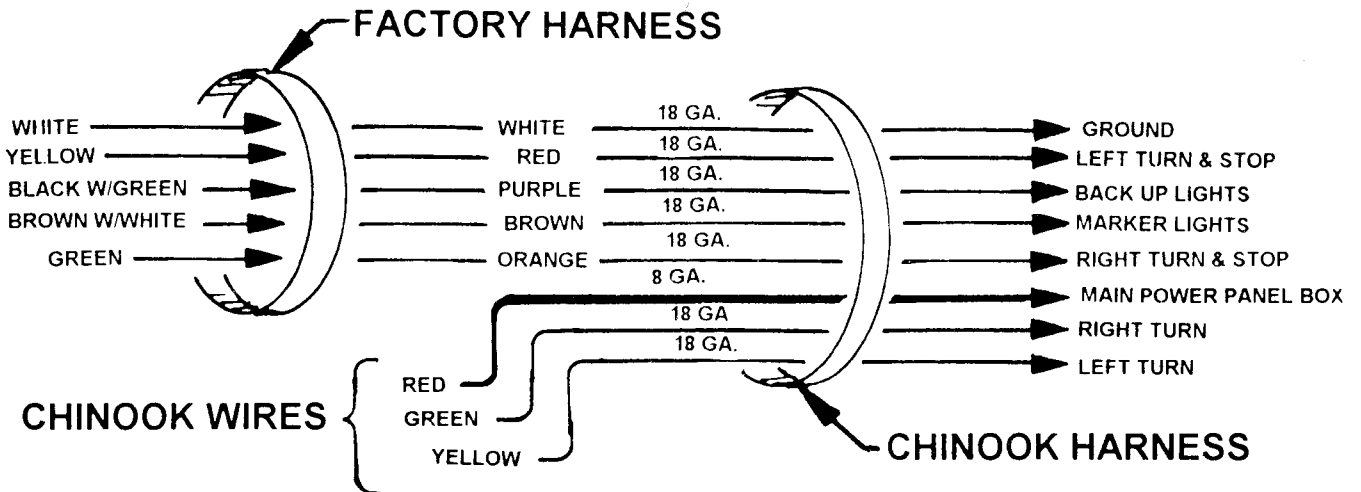

## CHINOOK CONTOURSE & PREMIER RUNNING LIGHTS COLOR CODE CONVERSION

# ELECTRICAL SYSTEM

## 12 VDC auxiliary battery

### Power Converter

The power converter, located in a compartment under the sink cab and range automatically converts 120 VAC to 12 VDC to provide power for lighting and appliances. The converter operates only when the power cord is connected to a 120 VAC external source or when the optional generator is in operation.

### Circuit Protection

All 12 VDC circuits are protected with properly rated fuses or automatic reset circuit breakers. Three automatic circuit breakers are provided near the auxiliary battery located under the hood in the engine compartment. If either breaker trips because of a momentary surge, it will reset automatically after the overload is removed. If the breaker continues to trip, however, the system should be checked by a repairman to determine the cause.

Main 12 VDC converter circuits are protected by fuses located inside the converter. Access to these fuses is by opening the hinged cover on the face of the converter.

## 12 VAC external source

Your Chinook motorhome is provided with a 25 ft. power cord for connection to an external 120 VAC 30 amp receptacle. When leaving campsite, be sure the cord is removed from the receptacle and stowed in its compartment. Failure to store it properly could result in extensive damage.

**CAUTION:** The use of cord cap adaptors must not be permitted because this could result in connecting the motorhome to an improperly rated source.

### Portable Appliances

You will find 120 VAC convenience outlets provided inside your motorhome to supply power for portable appliances.

# WATER SYSTEM

As a completely self-contained unit, your Chinook motorhome enables you to supply portable water to fixtures by two methods.

## Storage tank

First, fresh water may be drawn by the demand water pump from a storage tank under the driver's side folding seat. The water pump switch is on the system's monitor panel. Once the switch is turned on, the system operates automatically and the pump turns itself on and off by sensing a pressure drop in the line when a faucet is opened.

The water pump switch should be turned off when the water system is not in use. The fresh water tank is filled using the water tank fill port on the outside of the driver's side.

## Municipal water

Second, direct connection may be made to a city water pressure system through an inlet fitting on the driver's side exterior of the motorhome.

When using the city water hookup, it is not necessary to operate the demand water pump. The city water inlet fitting contains a pressure regulator limiting the system pressure to 125 psi. This prevents damage to the piping caused by excessively high supply pressures such as those encountered at some campsites.

## Draining the Fresh Water System

Periodically it is necessary to drain the fresh water system. This is done by opening the water tank drain valve (located under the sofa on the driver's side at each end of the tank) and the water heater drain valve (just inside the water heat access cover on the driver's side exterior).

**NOTE:** If your motorhome is used frequently, you can leave water in the tank. Keep it sweet by adding a teaspoonful of soda to every fourth or fifth tank of water. For long periods of time between use, drain the tank completely except for a teaspoonful of soda and two gallons of water. When you are ready to use the unit again, refill the tank and drain completely, then refill with fresh water.

# WATER SYSTEM

## Waste water holding system

Two water holding tanks are installed on your motorhome. They are located under the coach at the rear. One tank is used to contain waste water from the galley sink, shower sink and the shower. The other contains only waste from the toilet.

## Draining the Waste Holding Tanks

When your holding tanks require emptying, follow these steps:

1. Locate an outlet where they may be drained. This may be a gas station which has septic tank pumping facilities, a trailer park or a supply and service facility. Guidebooks contain these locations.
2. Park next to the inlet where you will dump the waste.
3. Remove the flexible hose from the storage tube under the motorhome. Making sure the drain valves are closed, (T handles all the way in), remove the drainage cap, insert the hose connector and tighten.
4. Insert the opposite end of the hose into the pump tank inlet.
5. Open the valves by pulling the T handles all the way out.
6. When the tanks are empty, close the valves and secure them. The system is now completely drained and ready for use. Periodically, flush the system with the water provided at the septic tank facilities.
7. Return the flexible hose to its storage tube and secure the cap.

## Care of the Holding Tanks

From time to time add a gallon or two of water containing liquid detergent into the holding tanks. The movement of the water and detergent when the vehicle is in motion will serve to clean the tanks. Use of a holding tank deodorant prevents excessive odor from the tanks. Several products are generally available for this purpose.

## Winterizing

Drain the fresh water system and waste holding tanks; add a recommended solution to prevent freezing in traps and other water filled cavities in the drainage system only.

**WARNING:** Do not use antifreezes other than those recommended for plastic pipe and recreational vehicles.

# WATER SYSTEM

## Systems monitor panel

Your Chinook motorhome is equipped with a systems monitor that tells you at the press of a button the levels of contents in your fresh water tank, waste water holding tank, toilet waste holding tank and LP gas.

Additional features of this systems monitor include an auxiliary battery condition meter, water pump switch, range hood light and exhaust fan.

To reset your clock, simply remove the glass cover over the clock face and move the hands to the desired position and reset the glass cover firmly into place. The clock battery should last approximately one year.

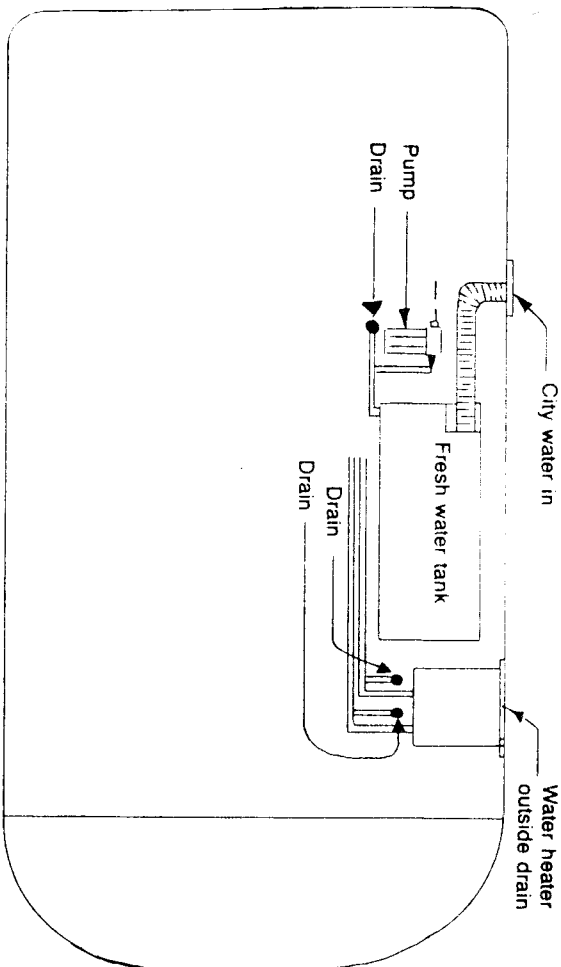

**Fresh Water Drain and Fill System**

# LP GAS SYSTEM

LP-gas is supplied to your appliances from a storage tank located under the motorhome on the passenger side forward of the rear wheels. The main supply shut-off valve for the system is called the tank service valve and is located on the tank. The high pressure of the storage tank is reduced to appliance operating pressure by a two-stage regulator attached to the main supply valve. Fuel passing through this regulator is distributed to the various appliances by a system of steel tubing.

## Operation of gas appliances

Appliances that operate on LP-gas include the furnace, water heater, range and refrigerator (at the user's option).

Each appliance is supplied with a manufacturer's operating instruction booklet. To assure safe, trouble-free operation, read these instructions completely before using any of the LP-gas appliances.

## Furnace Installation Note

The furnace installed in your motorhome may have an LP-gas shut-off valve in the supply line as part of the manufacturer's requirements. This valve is located in one of two areas — adjacent to the furnace inside the motorhome or outside under the floor forward of the passenger side rear wheels. Determine the location of this valve immediately because its use is required as part of the furnace manufacturer's operating instructions.

## Safe Operation and Maintenance

1. Familiarize yourself with the distinctive odor of LP-gas.
2. Check the entire system for possible leaks and missing or damaged parts before and after each trip, when filling the storage tank and any time you suspect trouble.
3. If a leak is suspected, immediately turn off the main service valve on the tank and ask your LP-gas dealer to check the system.
4. In an emergency, the tank service valve must be readily accessible. Never attach a lock or device requiring a key, special tools or knowledge to open or close this valve.
5. When the LP-gas system is not in use, turn off the gas supply at the tank.
6. Never use a wrench to tighten the tank service valve. It is designed to be closed leak tight by hand. If a wrench is required to close or open the valve, it must be repaired or replaced.
7. Read and observe the tank manufacturer's instructions. They will explain the operation of all tank controls, including the level gauge, tank fill connection, service valve and 20% vapor valve.

# LP GAS SYSTEM

## Safe operation and maintenance (continued)

8. Overfilling the storage tank can present a safety hazard. When the tank is filled the 20% vapor valve should be opened, which allows any liquid to escape until only gas is present. The valve should then be closed. This means the tank is 80% filled with liquid, which is the rated "Full" capacity of the tank.
9. Do not use an LP-gas storage tank other than the one furnished with your motorhome to supply your LP-gas system.
10. Do not tamper with LP-gas piping system, pressure regulator or appliances. Exercise caution when drilling holes or attaching objects to walls or floor area.
11. Be sure appliance, plumbing and outside vents are free of obstructions when operating any LP-gas appliance.
12. **THE LP-GAS TANK SHOULD BE FILLED ONLY BY QUALIFIED PERSONNEL AT AN LP-GAS DEALER SERVICE STATION.**

## Checking connections for leaks

Your Chinook motorhome is designed so all joints and connections in its LP-gas system are accessible for inspection. You should check these connections periodically by brushing a solution of water and liquid detergent on the fittings under pressure and watching for bubbles — an indication of escaping gas.

**WARNING: DO NOT USE A LIGHTED MATCH OR SIMILAR DEVICE TO DETECT LP-GAS LEAKS.**

## Special note on LP-gas

Unlike natural gas used in homes, LP-gas is heavier than air. This means that if a leak should occur in the system the escaping gas will seek the lowest level in a contained area.

Simply opening windows will not lessen the danger of explosion. If a leak is suspected, be sure to open all windows, doors, cupboards and drawers to allow any accumulated gas to flow to the exterior — and do not operate spark-or flame-producing devices such as matches, lighters, electric motors, switches, etc.

# GENERAL MAINTENANCE

## Caring for the exterior of your Chinook

Care for the exterior of your motorhome as you would for an automobile or boat finish.

The Chinook surface may be cleaned using car shampoo, mild detergents or household cleaners — but be sure to check the list which follows. Strong soaps and abrasive cleaners should not be used. Dirt or grime that has been ground into surfaces is easily removed with a good quality rubbing or polishing compound. Rinse well after washing.

**CAUTION: DO NOT USE GASOLINE OR PAINT THINNERS TO REMOVE TAR — THEY SOFTEN PAINT. USE A SPECIAL TAR REMOVER AND RINSE WELL WITH CLEAR WATER.**

The fiberglass and enamel surfaces may be waxed at any time; require no special methods, and do not rust or corrode. You do not have to wax before travelling to the ocean. Only metal surfaces are subject to salt air corrosion, so waxing them before driving to the seashore will improve their resistance.

Wash the surface before waxing with automotive or household waxes. A paste wax provides the best protection from abrasion and minor scratches because dirt slides readily from a well-waxed surface. The fiberglass becomes slightly dull or faded after long exposure to weather. You can easily restore it to its original luster and gloss by cleaning with a good rubbing compound and then waxing.

The exterior color key trim should be cared for as described above. Do not use gasoline or solvents. Clean with mild detergents and then wax to remove luster.

### What to use . . . what not to use

The following is a list of cleaners and waxes the factory has evaluated for use on exterior surfaces. This listing does not constitute an endorsement of the products named but is intended to serve only as a general guide.

Recommended:

1. Joy Detergent
2. Wisk Detergent
3. Liquid Lux
4. Johnson's Pride
5. Johnson's Pledge
6. Endust

# GENERAL MAINTENANCE

## Caring for the exterior of your Chinook (continued)

7. Camu
8. Turtle Wax auto polish
9. Simonize Body Sheen auto polish
10. Glo-Coat floor polish
11. Aero Wax
12. Holiday Car Cleaner
13. Meguiar's Mirror Glaze paste wax
14. Simonize paste wax
15. Sodium carbonate and bicarbonate
16. Vinegar

Not Recommended:

1. Gasoline
2. Carbon tetrachloride
3. Lestoil
4. Pine-sol
5. Lysol
6. Abrasives (cleaners)
7. Paint thinners or solvents containing aromatic and halogenated hydrocarbons (ketones, benzene, toluene, perchlorethylene).

# GENERAL MAINTENANCE

---

## Interior Care

For wood surfaces the same care and cleaning methods used in your home should be used in your motorhome. Strong soaps and abrasives should not be used, but cleaners containing small amounts of ammonia may be suitable.

Cabinet fronts need very little care. Treat them as you would any fine piece of furniture in your home.

The shower stall of your unit is constructed of rugged fiberglass. The finish will not chip or crack, but it can be cut or scratched. In the event that it is cut or scratched, use a good grade of rubbing or polishing compound. The color is cast into the fiberglass and will not fade. Never use steel wool or abrasive cleaners on your fiberglass — you simply add serious scratches by doing so.

Your floor is covered with top-grade carpeting. Maintain it exactly as you maintain your carpets at home.

The upholstery in your Chinook motorhome is a fine quality material and should be treated accordingly. If it gets wrinkled or out of shape through use, simply straighten it and fluff the foam cushions.

# PREVENTIVE MAINTENANCE

---

## Some things to check

Your privacy blinds will retain their color and beauty with occasional cleaning. You may order extra sets from your dealer.

You should make a general maintenance inspection of your motorhome periodically. Non-drying caulking compounds, available in tubes, may be used to seal around moldings and seams. These compounds are compatible with fiberglass and aluminum surfaces.

Epoxy-resin patch kits, also available in tube form, may be used to fill any small cracks or holes in the fiberglass. Patch and fiberglass care kits are available at most boat shops and marinas.

It is recommended that all chassis bolts be checked once a year for tightness to prevent rattles resulting from vibration.

If the exterior of your motorhome is punctured, immediately cover the puncture with a piece of waterproof material and tape. This will prevent moisture from getting through and damaging the interior. Keep the puncture patched in this manner until your dealer can repair it or refer you to a qualified service facility.

Ceramic counter tops must be silicone sealed every four months to avoid drying and cracking of the grout.

## Roof Inspection

Take care of your roof. Sealing around stacks and vents should be accomplished using non-drying caulking compounds. Hot summer sun can dry out caulking, and pronounced temperature changes can cause carrying degrees of expansion and contraction with various materials used in your roof and its components. These conditions may cause leaks, which is why you should inspect your roof regularly. By catching a problem in its early stages you can avoid serious repairs in the future.

Remember that the fiberglass roof of your Chinook motorhome has been designed to be waterproof, sturdy and soundproof. However, it was not built to carry high-density loads. **DO NOT WALK DIRECTLY ON THE ROOF.** When maintenance requires access to the roof, place plywood walkboards on the roof to prevent damage. Damage from walking on the roof could void your warranty. This would be at the discretion of the manufacturer.

# SPECIFICATIONS

## Chassis specs

Height  
 Outside ..... 9'2" - 9'9", with roof air  
 Inside ..... 6'4"  
 Width ..... 7'5"  
 Length ..... 20'9"  
 Weight (dry) ..... 8,600 lbs.

## Standard chassis

Dual rear wheels • Automatic transmission • Power assisted steering •  
 Rear anti-lock power assisted brakes • Heavy-duty suspension • Dual  
 outside rear view mirrors • Padded engine caddy and cover • Overdrive  
 (Fords only)

## RV specs

	PREMIER	CONCOURSE
LP gas	12 gal.	19 gal. with gauge
Gasoline tank	35 gal.	35 gal.
Fresh water system	36 gal.	36 gal.
Hot water tank	6 gal./rapid recovery	6 gal./rapid recovery
Refrigerator	4.5 cu. ft.	Double door 6 cu. ft.
Holding tanks - dual	38 gal.	38 gal.
Heater	12,000 BTU Super fan-forced air electric start furnace	16,000 BTU Super fan-forced air electric start furnace
Range	2-burner cook top	3-burner LP gas range and range cover
Lighting	12V and 120V systems	12V and 120V systems
Converter	32 amp battery charger and distribution panel	32 amp battery charger and distribution panel
Receptacles	Interior 120 volt outlets	Interior 120 volt outlets

## Bed Sizes:

Dinette ..... wall-to-wall king size, 6' long  
 Club ..... sofa sleeper plus 2 barrel chairs  
 Twin ..... inner spring mattresses, stationary, 72"x33"

SPECIFICATIONS SUBJECT TO CHANGE WITHOUT NOTICE.